



PRODUCT HIGHLIGHTS

- Provides stereo mix control of sixteen audio channels
- Channel volume and pan control with LED readout
- Dedicated Recall, Group, Solo, and Mute buttons
- Sixteen user Preset memory locations
- Master Volume, Treble, and Bass controls
- Balanced XLR and 1/4" TRS outputs
- Balanced 1/4" TRS inserts
- Auxiliary stereo mix in
- MIDI control over mix and preset save/recall
- Optional A-16CS wired remote control

The A-16R rack-mount Personal Mixer provides performers with independent mix control of a sixteen-channel monitor feed. With the A-16R, each performer can independently control each channel's volume, pan/stereo spread, and grouping, as well as master volume and tone. The A-16R is specifically designed for users of wireless in-ear monitors or floor wedges, and for applications where both an engineer and a performer need control over the monitor mixes.

Each A-16R can store up to sixteen custom mix snapshots. Individual channels, channel pairs, or groups can be soloed or muted. An auxiliary stereo mix input supports input of local audio such as a click track.

The A-16R provides balanced line-level outputs on XLR or 1/4" TRS jacks. Insert send and return points are provided via balanced 1/4" TRS jacks. MIDI In, Out, and Thru jacks provide the ability to save/load settings or select A-16R presets via MIDI.

The optional A-16CS Control Surface provides remote control of channel mixing functions, as well as master volume and tone and saving/recalling Presets. With the A-16CS, the A-16R

can be placed offstage in an equipment rack with other gear, such as IEM transmitters, while still allowing the performer to control the monitor mix. With the A-16R placed in the wings near an engineer and the A-16CS near the performer, the system provides control to both the performer and the engineer, allowing efficient collaboration on mixes and allowing engineers to limit maximum output volumes on stage. The A-16CS is connected to the A-16R with a single Cat-5e cable, up to 200ft (60m).

Audio is provided to the A-16R on a Cat-5e cable via Aviom's ultra-fast A-Net® Pro16™ protocol. A-Net Pro16 supports plug-and-play operation, long cable runs (up to 500ft/150m between devices), and 24-bit uncompressed digital audio. Personal Mixers can be connected in series or in parallel, using the A-16D or A-16D Pro A-Net Distributors. Power can be supplied locally with an external DC power supply or remotely, over the Cat-5e cable, using an A-Net Distributor.

The A-16R Personal Mixer can be used in virtually any combination with other Pro16 devices. There is no limit to the number of Personal Mixers that can be used in a system.

A-16R PERSONAL MIXER SPECIFICATIONS

Audio Outputs	Impedance matched output
Headphone Output	Front panel: TRS: Tip: Audio Left; Ring: Audio Right; Sleeve: Ground
Mix input, stereo	Balanced 1/4" TRS; front-panel volume control
Insert send/return	Balanced 1/4" TRS
A-Net I/O	1 A-Net In, 1 A-Net Out; RJ45 connectors
D/A Conversion	44.1/48kHz, 24-bit
Indicators	Pan: 5 LEDs, 4 red, 1 green; Channel Volume: 12 red LEDs
Stereo Operation	Stereo Link, per channel pair; set at the input module Variable pan/spread per channel or channel pair
Tone Controls	Treble: +/-12dB at 9kHz shelving Bass: +/-12dB at 160Hz shelving
Output Impedance	140 ohms
Freq. Response	4Hz-22kHz +0.2dB/-3dB
THD +N	< .003%
Signal to Noise (unweighted)	-90dB typical, A/D to D/A Measured from AN-16/i to A-16II
Crosstalk	-90dB

Latency	0.880 msec (measured from analog input to analog output)
A-Net Pro16	uses unshielded Cat-5e UTP (or better) cable; maximum 500ft (150m) between devices
Remote Control	A-16CS: A-Control, RJ45 jack, max. 200 ft (60m)
Power Supply	External, DC, universal switching type Input Voltage 100-240 volts, 50/60Hz, 30VA Output Voltage 18-24 VDC, 0.5 amp Plug Size 2 mm
Dimensions, A-16R	19" (482.6 mm) x 6.7" (170.2 mm) , 1U high
Dimensions, A-16CS	10.75" (273 mm) x 5.6" (142.2 mm); 2.25" (57.5 mm) high
Weight	3.4 lbs (1.54 kilo)
Options	A-16CS Control Surface MT-1 Mic Stand Bracket (for A-16CS) EB-1 Extension Bracket
<i>All Aviom products are designed and manufactured in the USA.</i>	

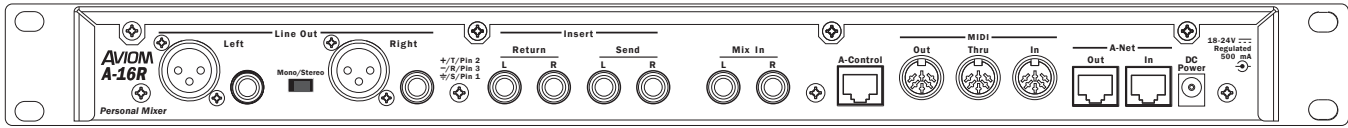

A-16R REAR PANEL FEATURES

- Balanced audio outputs
- Mono/Stereo switch
- Insert Send/Return
- Aux Mix In
- A-Control (to A-16CS)
- MIDI In, Out, Thru
- A-Net In, A-Net Out
- DC power

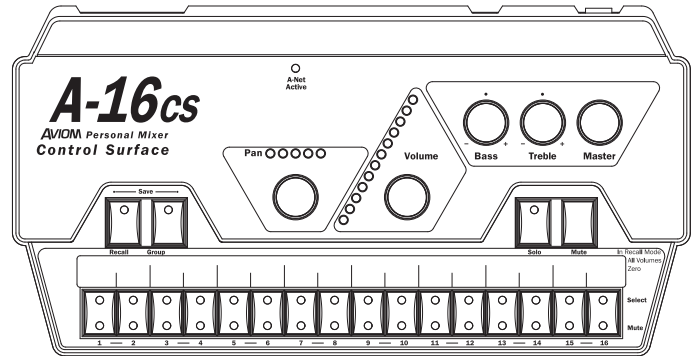

The optional A-16CS Control Surface allows the A-16R to be controlled from up to 200ft (60m) away.

A-16R BLOCK DIAGRAM

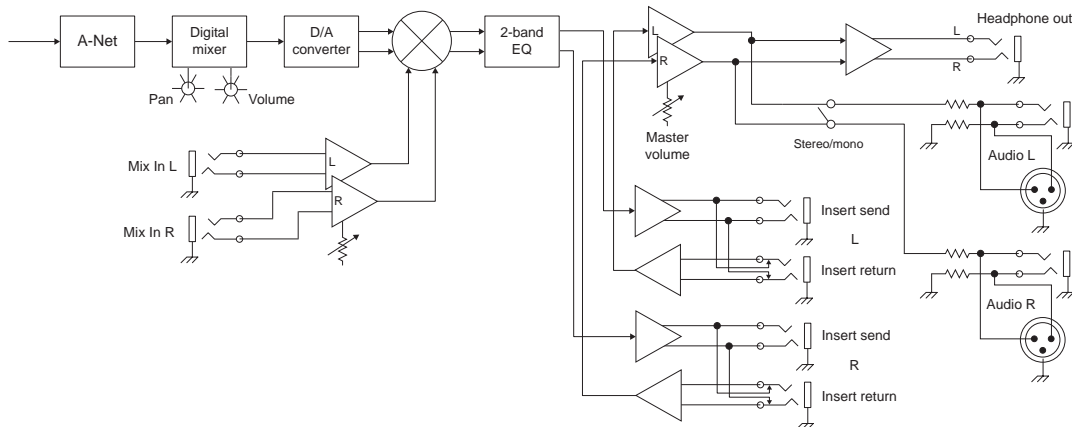

ARCHITECTURAL SPECIFICATION

The Aviom A-16R Personal Mixer shall provide stereo mixing for sixteen channels of audio transmitted via an A-Net Pro16 network over Cat-5e UTP cable. It shall provide full-bandwidth, high-quality audio by employing the Aviom A-Net Pro16 audio transmission protocol. It shall employ 24-bit D/A converters with a 44.1/48kHz sampling rate.

The audio output shall be capable of being connected to headphones or line-level audio sources. Output impedance shall be 140 ohms. Maximum level (RMS) shall be 1.0 watt at 100 ohms.

Front panel features shall include master volume, treble and bass controls, LED indicators for channel volume and pan, lighted channel-select buttons, mute and solo functions, Mix In volume control, and a 1/4" TRS stereo headphone output with level control. The unit shall be capable of storing sixteen mixes as presets in internal memory, as well as externally via MIDI. A front-panel switch shall be provided to select local or remote operation.

The unit shall be powered from an external universal power supply (input voltage 100 to 240 VAC; output voltage 18-24 VDC, 0.5 amps) and shall include a detachable DC power cord. It shall be UL and CE listed.

The A-16R rear panel shall have RJ45 connectors for A-Net digital signal input and output, and 5-pin DIN jacks for MIDI in, out, and thru. The unit shall employ parallel balanced XLR and 1/4" TRS jacks for line-level outputs, a stereo/mono switch, balanced 1/4" TRS insert send and return jacks, and stereo auxiliary mix inputs with balanced 1/4" TRS jacks. One RJ45 jack shall be supplied for connection of an optional wired remote control, the A-16CS Control Surface.

Its dimensions shall be 19 inches wide, 6.7 inches deep, and 1.75 inches (1U) high. Its net weight shall be 6.8 pounds, and its steel chassis shall be finished in blue. The unit shall be Aviom, Inc. model A-16R.

The A-16CS Control Surface shall provide remote operation of mix parameters of the A-16R Personal Mixer, when connected via Cat-5e cable to the A-Control port of the A-16R. The user interface of the A-16CS shall be functionally similar to that of the A-16II.

The A-16CS rear panel shall have one RJ45 jack for connection to the A-Control port of the A-16R host, which also supplies power to the A-16CS. Its dimensions shall be 10.75 inches wide, 5.6 inches deep, and 2.25 inches high. Its net weight shall be 3.4 pounds, and it shall be finished in blue. The unit shall be Aviom, Inc. model A-16CS.